

AM-150BWF

SELF-CONTAINED CUBER WITH BUILT-IN STORAGE BIN

Item # _____

Project: _____

Qty: _____

*AutoCad available on KCL

AM-150BWF

4/08

Item # 13228

CUBER DIMENSIONS

W x D x H

AM-150BWF

27^{11/16} x 27^{15/16} x 39*

*with 6" adj. legs

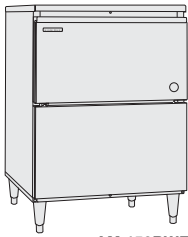

AM-150BWF

AM-150BWF

Water-Cooled
Shown



- Up to 150 lbs. of ice production per 24 hours
- Durable stainless steel exterior
- Up to 88 lbs. of built-in storage capacity
- Easily disassembled water circuit for easy cleaning
- Front in, front out airflow (Air-cooled model only)
- Fewer moving parts for longer life
- Drop down door
- R-404A Refrigerant



Warranty

Valid in United States, Canada, Puerto Rico, & U.S. Territories. Contact factory for warranty in other countries.

Three Year - Parts & Labor on entire machine.

Five Year - Parts on compressor and air-cooled condenser coil.

Five Year - Parts on evaporator.



AM-150BWF SELF-CONTAINED CUBER WITH BUILT-IN STORAGE BIN

DIMENSIONS
W x D x H
AM-150BWF
27^{11/16} x 27^{15/16} x 39^{5/8}
*with 6" adj. legs

• Water-cooled

WATER-COOLED

Water Temp° F.	50°
Air Temp° F.	70°
	150 lbs.

UTILITY CONSUMPTION (AIR 70°F/WATER 50°F)

Model Number	Ice Production Per Cycle		KWH per 100 LBS.	Potable Water Gal. per 100 lbs.	Condenser Water Gal. per 100 lbs.
	Lbs.	Cubes			
AM-150BWF	1.78	60	9.0	31	92

SPECIFICATIONS

Model Number	Condenser	Amperage	Min. Circuit Ampacity	Shipping Weight
AM-150BWF	Water-Cooled	7.0	N/A	192 lbs.

AM CUBE DIMENSIONS

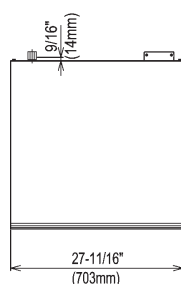
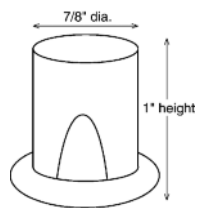

TOP DIMENSIONS

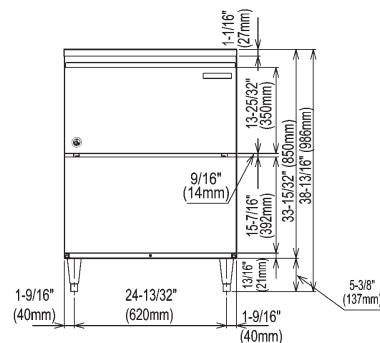

FRONT DIMENSIONS

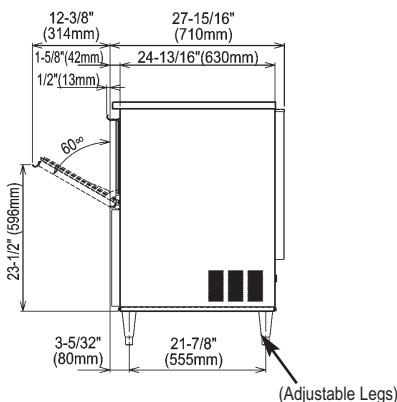

SIDE DIMENSIONS

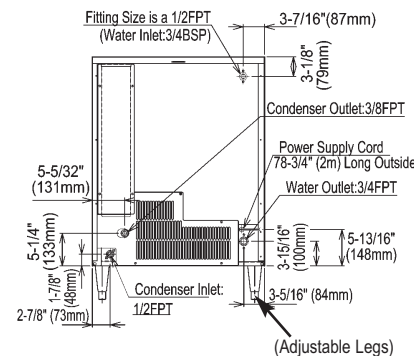

BACK DIMENSIONS

ELECTRICAL & PLUMBING/AM-150BWF

- 115V/60/1
- 15 amp Max Fuse/HACR Breaker Size
- 1/2" OD copper or equivalent independent potable water supply
- 3/4" independent drain connection
- 1/2" FPT Water Inlet

OPERATING LIMITS

- Ambient Temp Range 50 - 100°F
- Water Temp Range 41 - 90°F
- Water Pressure 7 - 113psig
- Voltage Range 104 - 127V



© HOSHIZAKI AMERICA, INC.

618 Hwy. 74 S., Peachtree City, GA 30269

TEL 1-800-438-6087

FAX 1-800-345-1325

www.hoshizaki.com

Printed in U.S.A.

