

CGHE-1

product specifications

Commercial Grade Instant Hot Water Dispenser

Get luxurious instant hot water at the tap with the Everpure Commercial Grade Instant Hot Water Dispenser. The perfect complement to an Everpure commercial grade water filtration system, the CGHE-1 delivers great-tasting, piping-hot water on demand. This truly commercial grade unit offers a generous capacity of up to 100 cups of water per hour at 190°F. The CGHE-1 is a compact unit that provides instant hot water from your tap for coffee, tea, hot chocolate, oatmeal, pasta, soups and much more.

Combine with commercial grade water filtration

It's water filtration you can trust

The same commercial quality that makes Everpure the overwhelming choice for water filtration in restaurants is also available for your home. Everpure's exclusive precoat filtration technology combines Micro-Pure and a unique pleated filter membrane to reduce particles as small as 0.5 microns. This highly engineered design offers the largest filtering surface area, longer life and consistent performance.

The Everpure CGHE-1 Instant Hot Water Dispenser features:

- > Proven commercial-grade quality
- > Produces piping hot water on demand at 190°F
- > 100 cups of water per hour, delivering more volume than the competition
- > Compact unit mounts on wall in virtually any cabinet
- > Insulated stainless steel tank is energy efficient and maintenance free
- > Powerful 1300 watts for quicker recovery
- > Easy to install with quick-connect fittings
- > Fingertip temperature adjustment
- > Heater protection with self-resetting thermal fuse which prevents accidental dry starts
- > UL listed
- > Use with an Everpure Commercial Grade Water Filtration System or Reverse Osmosis System
- > Combine with an Everpure hot and cold drinking water faucet



iMarlin LLC
1200 E. Woodhurst Building V
Springfield, MO 65804
Ph: 417-885-4562 Fax: 417-889-6897

EVERPURE
WATER YOU CAN TRUST

CGHE-1

product specifications Commercial Grade Instant Hot Water Dispenser

CGHE-1 Commercial Grade Instant Hot Water Dispenser – Part No. EV9318-40

Features

- > True commercial grade quality, delivering up to 100 cups of hot water per hour.
- > 5/8 gallon stainless steel reservoir is insulated.
- > Non-pressurized tank with self contained expansion chamber.
- > Powder coated steel housing.
- > Quick connect fittings and removable drain plug.

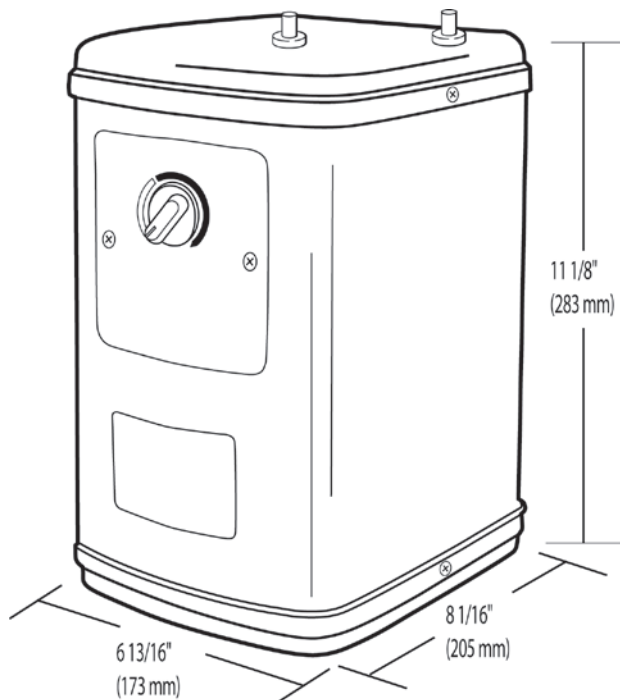

General Installation/Operation/Maintenance Requirements

- > Measures 11.2" high x 6.8" wide x 8.1" deep.
- > Thermostat can be adjusted from 140°F to 190°F.
- > Open vent faucet is required. Connecting to a standard faucet will damage the tank and void the warranty.
- > Power cord installed.

capacity

100 cups per hour

temperature output

140°F to 190°F

tank volume

5/8 gallon

inlet/outlet

1/4" O.D. tubes

power

1300 watts; 10.8 amps

electrical

120 volts, 50Hz

everpure warranty

The CGHE-1 instant hot water dispenser is warranted to be free from defects for one year from date of purchase. A detailed warranty statement is included with each unit.

Everpure, LLC

1040 Muirfield Drive

Hanover Park, IL 60133 USA

Phone: (630) 307-3000

FAX: (630) 307-3030

Customer Service: (800) 323-7873

Technical Service: (800) 942-1153

www.everpure.com

