

F-1500M_H

MODULAR FLAKER ICE MACHINE

Item # _____

Project: _____

Qty: _____

*AutoCad available on KCL

F-1500M_H

4/08

Item # 13161

FLAKER DIMENSIONS

W x D x H

F-1500M_H

30 x 27^{1/2} x 34^{7/16}



B-500



B-700

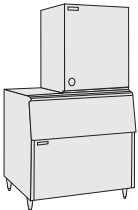

B-800

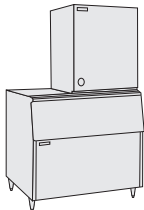

B-900



F-1500MAH

Air-Cooled

Shown on an optional
B-900

F-1500MWH

Water-Cooled

F-1500MRH

Remote Air-Cooled

Also available on Large Bins:

B-1150SS

B-1300SS

B-1500SS

B-1650SS

- Up to 1590 lbs. of ice production per 24 hours
- Durable stainless steel exterior
- CleanCycle I2® Design 
- 15 minute flush cycle every 12 hours
- Removes sediment
- Cleaner ice
- Longer life and easy maintenance
- R-404A Refrigerant



Warranty

Valid in United States, Canada, Puerto Rico, & U.S. Territories. Contact factory for warranty in other countries.

Two Year - Parts & Labor on entire machine.

Five Year - Parts on Compressor, air-cooled condenser coil.



F-1500M_H FLAKER ICE MACHINE MODULAR SERIES

DIMENSIONS
W x D x H
F-1500M_H
30 x 27^{1/2} x 34^{7/16}

- Air-cooled
- Water-cooled
- Remote Air-cooled

AIR-COOLED

| Water Temp° F. | 50° | 70° | 90° |
|------------------|------|-------------|------|
| Air Temp° F. 70° | 1590 | 1514 | 1447 |
| Air Temp° F. 80° | 1382 | 1321 | 1262 |
| Air Temp° F. 90° | 1206 | 1170 | 1100 |

WATER-COOLED

| Water Temp° F. | 50° | 70° | 90° |
|------------------|------|-------------|------|
| Air Temp° F. 70° | 1435 | 1390 | 1360 |
| Air Temp° F. 80° | 1335 | 1310 | 1285 |
| Air Temp° F. 90° | 1260 | 1245 | 1210 |

REMOTE AIR-COOLED

| Water Temp° F. | 50° | 70° | 90° |
|------------------|------|-------------|------|
| Air Temp° F. 70° | 1585 | 1532 | 1484 |
| Air Temp° F. 80° | 1439 | 1394 | 1351 |
| Air Temp° F. 90° | 1309 | 1300 | 1230 |

UTILITY CONSUMPTION

| Model Number | KWH per 100 LBS. 90/70 | Potable Water Gal. per 100 lbs. |
|--------------|------------------------|---------------------------------|
| F-1500MAH | 3.83 | 12.0 |
| F-1500MWH | 3.4 | 12.0 |
| F-1500MRH | 3.72 | 12.0 |

SPECIFICATIONS

| Model Number | Condenser | Amperage | Min. Circuit Ampacity | Shipping Weight |
|--------------|-------------------|----------|-----------------------|-----------------|
| F-1500MAH | Air-Cooled | 16.3 | 20 | 325 lbs. |
| F-1500MWH | Water-Cooled | 15.9 | 20 | 325 lbs. |
| F-1500MRH | Remote Air-Cooled | 18.9 | 20 | 325 lbs. |

STORAGE BINS

| Model Number | Application Capacity | ARI-Rated Capacity |
|--------------|----------------------|--------------------|
| B-500 | 500 lbs. | 360 lbs. |
| B-700 | 700 lbs. | 550 lbs. |
| B-800 | 800 lbs. | 600 lbs. |
| B-900 | 900 lbs. | 660 lbs. |
| B-1150 | 1150 lbs. | N/A |
| B-1300 | 1275 lbs. | N/A |
| B-1500 | 1490 lbs. | N/A |
| B-1650 | 1605 lbs. | N/A |

ELECTRICAL & PLUMBING/F-1500M_H

- 208-230V/60/1 (3 wire with dedicated neutral for 115V)
- 1/2" OD copper or equivalent independent potable water supply
- 3/4" FPT independent drain connection

OPERATING LIMITS

- Ambient Temp Range 45 - 100°F
- Water Temp Range 45 - 90°F
- Water Pressure 10 - 113psig
- Voltage Range 187 - 253V

SERVICE

- Panels easily removed and all components accessible for service.
- Removable/cleanable air filter. (Air-Cooled models only)

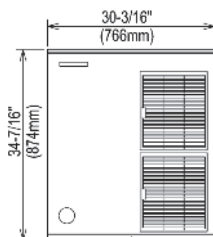

FRONT VIEW

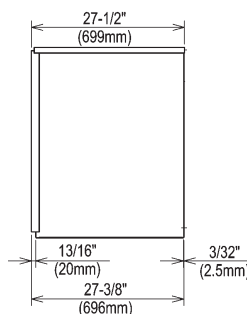

SIDE VIEW

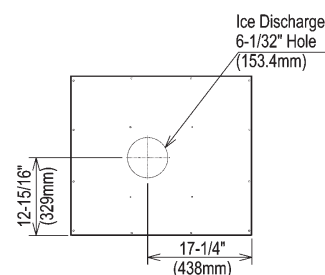

ICE DROP ZONE

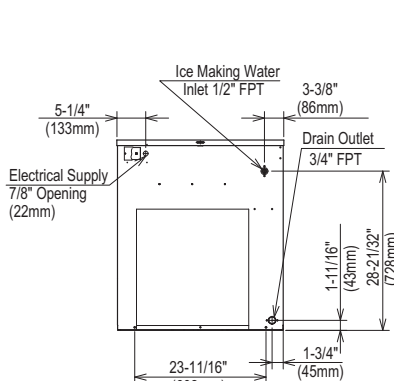

AIR-COOLED UNIT

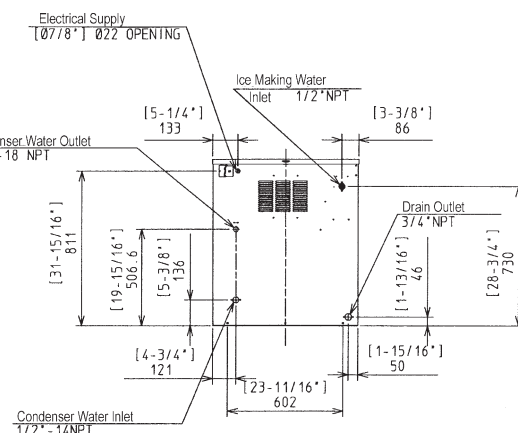

WATER-COOLED UNIT

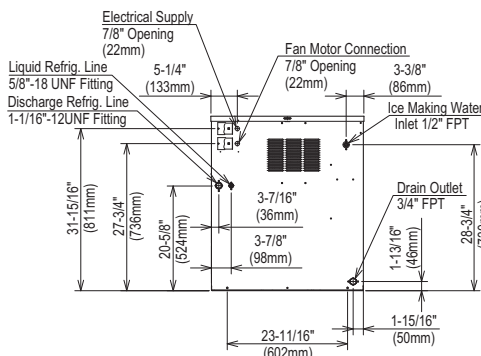

REMOTE AIR-COOLED UNIT

URC-12F Remote Condenser (Sold Separately) For Use with F-1500MRH

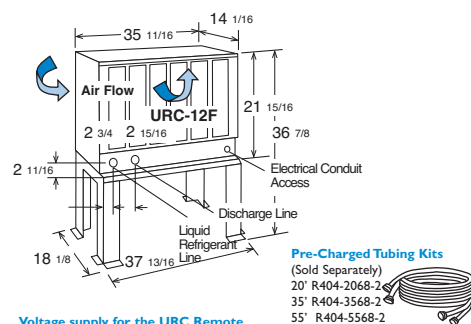

Voltage supply for the URC Remote Condenser is supplied from the Ice Maker. No additional circuit is required.

Pre-Charged Tubing Kits
(Sold Separately)
20' R404-2068-2
35' R404-3568-2
55' R404-5568-2



© HOSHIZAKI AMERICA, INC.

618 Hwy. 74 S., Peachtree City, GA 30269

TEL 1-800-438-6087

FAX 1-800-345-1325

www.hoshizaki.com

Printed in U.S.A.

