

# F-330BAH

## SELF-CONTAINED FLAKER WITH BUILT-IN STORAGE

Item # \_\_\_\_\_

Project: \_\_\_\_\_

Qty: \_\_\_\_\_

\*AutoCad available on KCL

F-330BAH

4/08

Item # 13200

### FLAKER DIMENSIONS W x D x H

**F-330BAH**  
24 x 26 x 39\*  
\*with 6" legs



**F-330BAH**  
Air-Cooled  
Shown

- Up to 330 lbs. of ice production per 24 hours
- Up to 80 lbs. built-in storage
- Corrosion resistant stainless steel
- Automatic flush system designed for longer life and dependability of ice machine
- Evaporator assembly protected from peak loads
- Convenient drop down door
- Front access for easier maintenance
- Removable air filter
- Front in, front out airflow - allows for easier fit into tight spaces with no clearance needed on sides and rear
- R-404 Refrigerant
- Protected by *HoshiGuard* Antimicrobial Agent 



### Warranty

Valid in United States, Canada, Puerto Rico, & U.S. Territories. Contact factory for warranty in other countries.

**Two Year** - Parts & Labor on entire unit.

**Five Year** - Parts on: Compressor, air-cooled condenser coil.



# SELF-CONTAINED FLAKER WITH BUILT-IN STORAGE BIN

F-330BAH

## DIMENSIONS

W x D x H

F-330BAH  
24 x 26 x 39"  
\*with 6" legs

• Air-cooled

## AIR-COOLED

Water Temp° F.	50°	70°	90°	
Air Temp° F.	70°	330	315	300
	80°	290	280	270
	90°	255	250	235

## UTILITY CONSUMPTION

Model Number	KWH per 100 LBS.		Potable Water Gal. per 100 lbs.
	90/70	70/50	
F-330BAH	5.8	4.1	12.0

## SPECIFICATIONS

Model Number	Condenser	Amperage	Min. Circuit Ampacity	Shipping Weight
F-330BAH	Air-Cooled	6.7	N/A	178 lbs.

## STORAGE BINS

Model Number	Application Capacity
F-330BAH	Built-in 80 lb. capacity

- Circuit breaker or fuse protects gear motor from overload.
- Gear motor runs one minute after termination of ice making to clear all ice from evaporator.

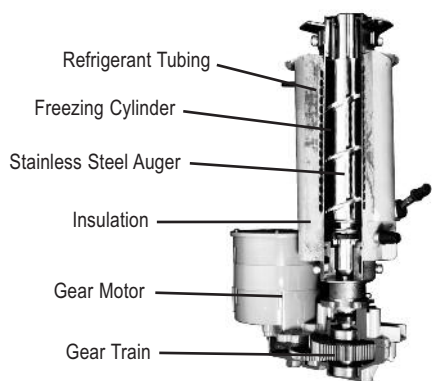

EVAPORATOR

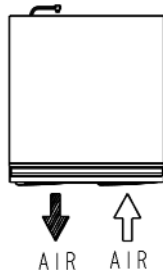

TOP VIEW

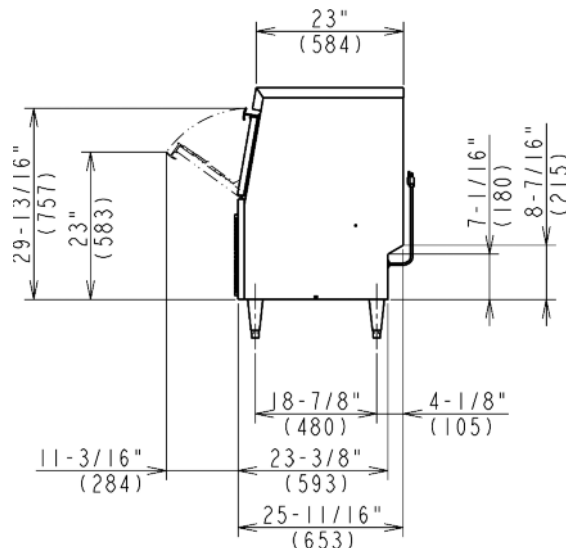

SIDE VIEW

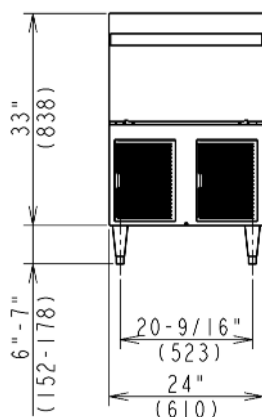

FRONT VIEW

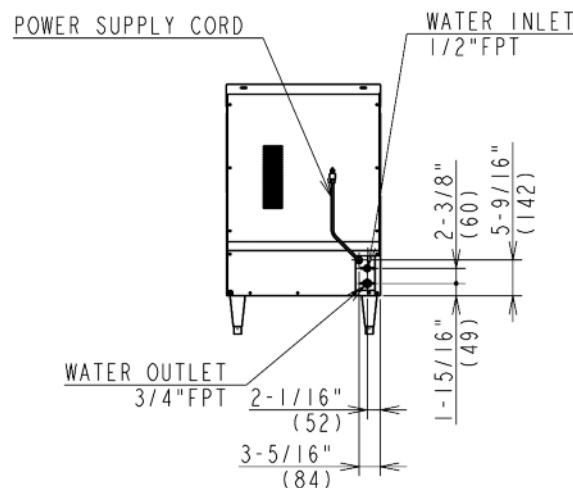

REAR VIEW

## ELECTRICAL & PLUMBING/F-330BAH

- 115V/60/1
- 1/2" OD copper or equivalent independent potable water supply
- 3/4" FPT independent drain connection

## OPERATING LIMITS

- Ambient Temp Range 45 - 100°F
- Water Temp Range 45 - 90°F
- Water Pressure 10 - 113psig
- Voltage Range 104 - 127V

## SERVICE

- Panels easily removed and all components accessible for service.
- Removable/cleanable air filters



© HOSHIZAKI AMERICA, INC.

618 Hwy. 74 S., Peachtree City, GA 30269

TEL 1-800-438-6087

FAX 1-800-345-1325

www.hoshizaki.com

Printed in U.S.A.

