

KM-250BWF

CRESCENT CUBER WITH BUILT-IN STORAGE BIN

Item # _____

Project: _____

Qty: _____

*AutoCad available on KCL

KM-250BWF

4/08

Item # 13201

CUBER DIMENSIONS W x D x H

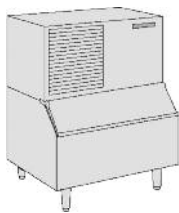

KM-250BWF
25 x 28 x 39



KM-250

KM-250BWF Water-Cooled Shown



- Up to 233 lbs. of ice production per 24 hours
- Built-in 100 lbs. ice storage
- Individual crescent cube
- Protected by *HoshiGuard* Antimicrobial Agent 
- CycleSaver® Design 
- EverCheck® alert system 
- Stainless steel evaporator
- Corrosion-resistant stainless and PVC exterior surfaces provide longer life
- Stainless steel evaporator
- Removable air filter



Warranty

Valid in United States, Canada, Puerto Rico, & U.S. Territories. Contact factory for warranty in other countries.

Three Year - Parts & Labor on entire machine.

Five Year - Parts & Labor on: Evaporator.

Five Year - Parts on: Compressor, air-cooled condenser coil.



KM-250BWF CRESCENT CUBER WITH BUILT-IN STORAGE BIN

DIMENSIONS

W x D x H
KM-250BWF
25" x 28" x 39"
*with adj. 6" legs

• Water-cooled

WATER-COOLED

Water Temp° F.	50°	70°	90°	
Air Temp° F.	70°	233	225	212
	80°	227	215	200
	90°	225	207	192

UTILITY CONSUMPTION

Model Number	Ice Production Per Cycle		KWH per 100 LBS. 90/70	Potable Water Gal. per 100 lbs.	Condenser Water Gal. per 100 lbs.
	Lbs.	Cubes			
KM-250BWF	3.98	200	9.9	39.5	136

SPECIFICATIONS

Model Number	Condenser	Amperage	Shipping Weight
KM-250BWF	Water-Cooled	7.5	190 lbs.

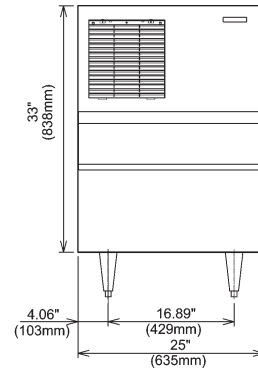

FRONT VIEW

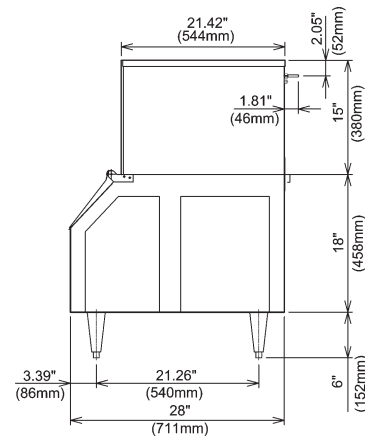

SIDE VIEW

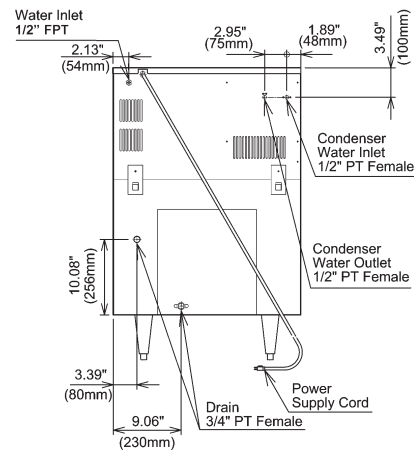

REAR VIEW

ELECTRICAL & PLUMBING/KM-250BWF

- 115V/60/1
- 1/2" OD copper or equivalent independent potable water supply
- 3/4" FPT independent drain connection
- 1/2" FPT Water inlet

OPERATING LIMITS

- Ambient Temp Range 45 - 100°F
- Water Temp Range 45 - 90°F
- Water Pressure 10 - 113psig
- Voltage Range 104 - 127V

SERVICE

- Panels easily removed and all components accessible for service.
- Removable/cleanable air filters



© HOSHIZAKI AMERICA, INC.

618 Hwy. 74 S., Peachtree City, GA 30269

TEL 1-800-438-6087

FAX 1-800-345-1325

www.hoshizaki.com

Printed in U.S.A.

