

KM-650MAH-E

SLIM-LINE MODULAR CRESCENT CUBER

Item # _____

Project: _____

Qty: _____

*AutoCad available on KCL

KM-650MAH-E

8/08

Item # 13054

CUBER DIMENSIONS

W x D x H

KM-650MAH-E

56 x 69.5 x 95cm

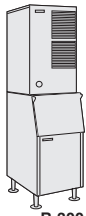

B-300

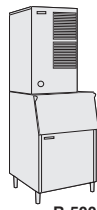

B-500

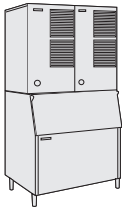

B-700



B-800

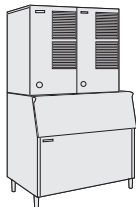



B-900

KM-650MAH-E

Air-Cooled

Shown on an optional
B-300



- Up to 296 kgs. of ice production per 24 hours
- Durable stainless steel exterior
- Individual crescent cube
- Protected by *HoshiGuard* Antimicrobial Agent 
- CycleSaver® Design 
- EverCheck® alert system 
- Stainless steel evaporator
- Mount two units side-by-side, in only 112cm of floor space, for 592 kgs. per 24 hours
- R-404A Refrigerant

Also available on Large Bins:
B-1150SS
B-1300SS



Warranty

Contact factory for warranty information.



KM-650MAH-E SLIM-LINE MODULAR CRESCENT CUBER

DIMENSIONS
W x D x H
KM-650MAH-E
56 x 69.5 x 95cm

• Air-cooled

AIR-COOLED

Water Temp° C.	10°	21°	32°
Air Temp° C.	21°	277	253
	27°	281	229
	32°	277	230

UTILITY CONSUMPTION at 32°C A/ 21°C W

Model Number	Ice Production Per Cycle Kgs. Cubes	KWH per 45 Kgs.	Potable Water Liters per 45 kgs.	Condenser Water Liter per 45 kgs.
KM-650MAH-E	6.4 720	5.7	70.0	N/A

SPECIFICATIONS

Model Number	Condenser	Amperage	Min. Circuit Ampacity	Shipping Weight
KM-650MAH-E	Air-Cooled	6.8	15 A	91 kgs.

STORAGE BINS

Model Number	Application Capacity
B-300	136 kgs.
B-500	227 kgs.
B-700	318 kgs.
B-800	363 kgs.
B-900	409 kgs.
B-1150	522 kgs.
B-1300	578 kgs.

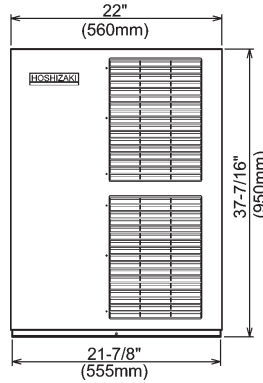

FRONT VIEW

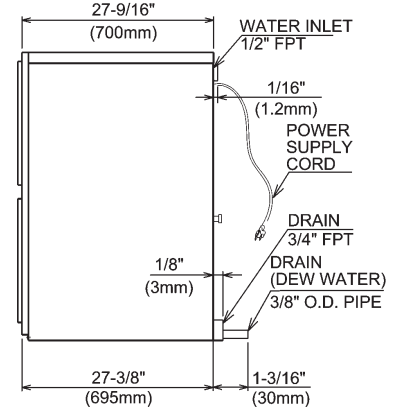

SIDE VIEW

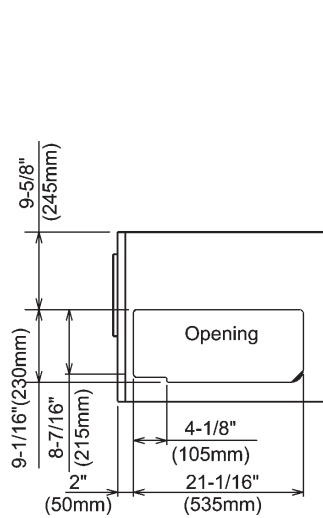

ICE DROP ZONE

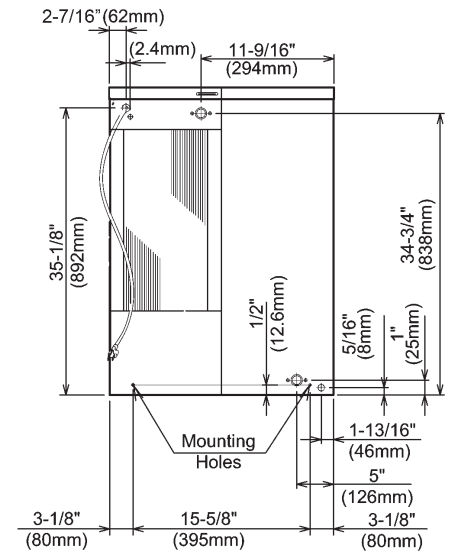

AIR-COOLED UNIT

ELECTRICAL & PLUMBING/KM-650MAH-E

- 220-240/50/1
- 15 Amp Max Fuse/HACR Breaker Size
- 0.95cm OD copper or equivalent independent potable water supply
- 3/4" FPT independent drain connection

OPERATING LIMITS

- Ambient Temp Range 7 - 38°C
- Water Temp Range 7 - 32°C
- Water Pressure 0.7 - 8 kg/cm²
- Voltage Range 198 - 254V

SERVICE

- Panels easily removed and all components accessible for service.
- Removable/cleanable air filters.



© HOSHIZAKI AMERICA, INC.

618 Hwy. 74 S., Peachtree City, GA 30269

TEL 1-800-438-6087

FAX 1-800-345-1325

www.hoshizaki.com

Printed in U.S.A.

