

KML-451M_H

LOW-PROFILE MODULAR CRESCENT CUBER

Item # _____

Project: _____

Qty: _____

*AutoCad available on KCL

KML-451M_H

4/08

Item # 13211

CUBER DIMENSIONS

W x D x H

KML-451M_H
30 x 27^{3/8} x 22



B-250

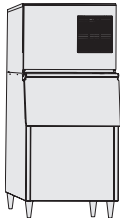

B-500

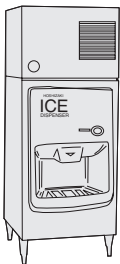

DB-200

Also available on
Bins:
B-700PF/SF
B-800PF/SF
B-900PF/SF

Large Bins:
B-1150SS
B-1300SS
B-1500SS
B-1650SS





KML-451MAH

Air-Cooled
Shown on an optional
B-500

KML-451MWH

Water-Cooled

- Up to 404 lbs. of ice production per 24 hours
- Durable stainless steel exterior
- Individual crescent cube
- Protected by *HoshiGuard* Antimicrobial Agent 
- CycleSaver® Design 
- EverCheck® alert system 
- Stainless steel evaporator
- Removable air filters
- R-404A Refrigerant
- Complies with California Energy Commission guidelines (CEC)



Warranty

Valid in United States, Canada, Puerto Rico, & U.S. Territories. Contact factory for warranty in other countries.

Three Year - Parts & Labor on entire machine.

Five Year - Parts & Labor on: Evaporator.

Five Year - Parts on: Compressor, air-cooled condenser coil.



KML-45IM_H LOW-PROFILE MODULAR CRESCENT CUBER

DIMENSIONS
W x D x H
KML-45IM_H
30 x 27^{3/8} x 22

- Air-cooled
- Water-cooled

AIR-COOLED

Water Temp ° F.	50°	70°	90°
Air Temp ° F.			
70°	403	387	355
80°	391	366	328
90°	387	349	313

WATER-COOLED

Water Temp ° F.	50°	70°	90°
Air Temp ° F.			
70°	404	402	384
80°	402	399	373
90°	402	397	374

UTILITY CONSUMPTION

Model Number	Ice Production Per Cycle		KWH per 100 LBS. 90/70	Potable Water Gal. per 100 lbs.	Condenser Water Gal. per 100 lbs.
	Lbs.	Cubes			
KML-451MAH	7.0	360	6.7	18.3	NA
KML-451MWH	6.8	360	5.3	19.7	138

SPECIFICATIONS

Model Number	Condenser	Amperage	Min. Circuit Ampacity	Shipping Weight
KML-451MAH	Air-Cooled	10.3	20A	185 lbs.
KML-451MWH	Water-Cooled	8.9	20A	185 lbs.

STORAGE BINS

Model Number	Application Capacity	ARI-Rated Capacity
B-250	250 lbs.	230 lbs.
B-500	500 lbs.	360 lbs.
B-700	700 lbs.	550 lbs.
B-800	800 lbs.	600 lbs.
B-900	900 lbs.	660 lbs.
B-1150	1150 lbs.	N/A
B-1300	1275 lbs.	N/A
B-1500	1490 lbs.	N/A
B-1650	1605 lbs.	N/A

ELECTRICAL & PLUMBING/KML-45IM_H

- 115/60/1
- 20 Amp Max Fuse/HACR Breaker Size
- 1/2" OD copper or equivalent independent potable water supply
- 3/4" FPT independent drain connection



© HOSHIZAKI AMERICA, INC.

618 Hwy. 74 S., Peachtree City, GA 30269

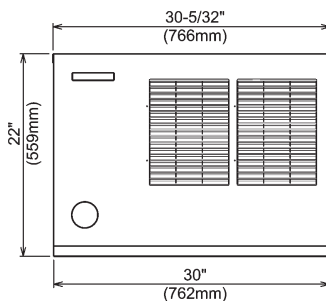

FRONT VIEW

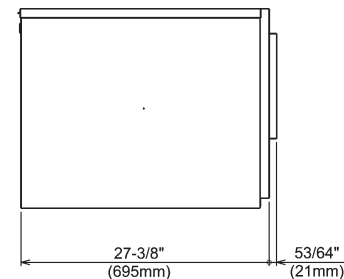

SIDE VIEW

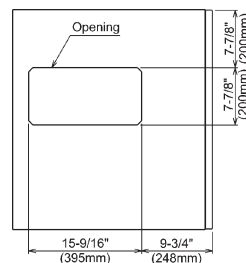

ICE DROP ZONE

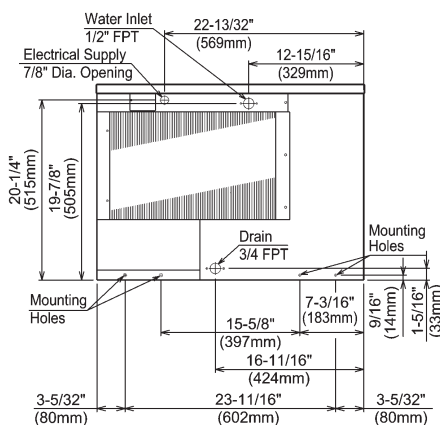

AIR-COOLED UNIT

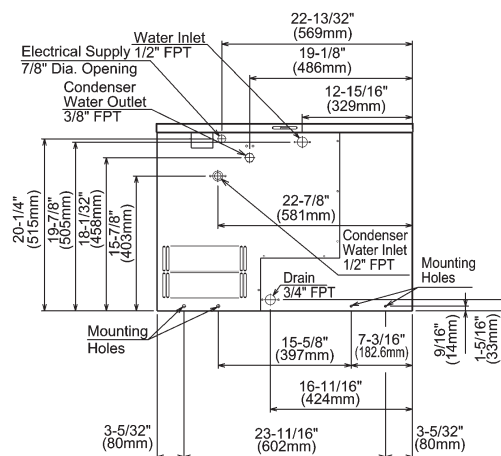

WATER-COOLED UNIT

OPERATING LIMITS

- Ambient Temp Range 45 - 100°F
- Water Temp Range 45 - 90°F
- Water Pressure 10 - 113psig
- Voltage Range 104 - 127V

SERVICE

- Panels easily removed and all components accessible for service.
- Removable/cleanable air filters

