

# DCM-300BAH-OS

Item # \_\_\_\_\_

Project: \_\_\_\_\_

Qty: \_\_\_\_\_

\*AutoCad available on KCL

## OPTI-SERVE SERIES SANITARY CUBELET ICE MACHINE/DISPENSER

DCM-300BAH-OS

12/11

Item # 13285

### DIMENSIONS W x D x H

#### DCM-300BAH-OS

26 x 22<sup>1/2</sup> x 40

#### SD-450

26<sup>1/4</sup> x 22 x 32<sup>1/2</sup>

#### SD-500

25<sup>9/10</sup> x 22 x 32<sup>3/4</sup>

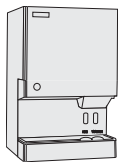

DCM-300  
Countertop

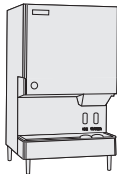

DCM-300  
Countertop  
with optional  
6" legs

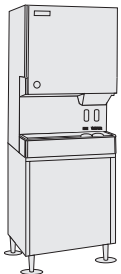

DCM-300  
Floor Model  
with optional  
stand

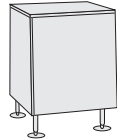

SD-450  
optional  
stand

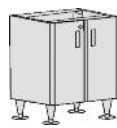

SD-500  
optional  
stand



### DCM-300BAH-OS

Air-Cooled  
Shown on an optional  
**SD-500 Stand**



\*Transparent drinkware may affect dispensing operations

### DCM-300BAH-OS

- CleanCycle 12® - Every 12 hours, unit performs 15 minute purge to rid itself of impurities 
- LED Remote sensor for hands-free operation
- Sealed LED housing prevents moisture from entering, eliminating the possibility of an electrical short
- Corrosion resistant stainless steel exterior
- Up to 321 lbs. of ice production per 24 hours, with 40 lbs. built-in storage
- Easy to chew, cubelet ice
- Self contained design reducing opportunities for cross contamination
- Dispenses ice and water
- Removable air filters (Air-cooled model only)
- Protected by H-GUARD Plus Antimicrobial Agent 

### SD-450 Stand / SD-500 Stand

- Heavy duty stand for floor model icemaker/dispenser
- Corrosion resistant stainless steel exterior
- Easy cleaning with attractive appearance
- Locking doors standard on SD-500



ISO9001-ISO14001

### Warranty

Valid in United States, Canada, Puerto Rico, & U.S. Territories. Contact factory for warranty in other countries.

**Three Year** - Parts & Labor on entire machine. (Serial numbers Vxxxxxj) and after.)

**Five Year** - Parts on: Compressor, air-cooled condenser.



# DCM-300BAH-OS SANITARY CUBELET ICE MACHINE/DISPENSER - OPTI-SERVE SERIES

## DIMENSIONS

	W x D x H		
<b>DCM-300BAH-OS</b>	26	22 <sup>1/2</sup>	40
<b>SD-450</b>	26 <sup>1/4</sup>	22	32 <sup>1/2</sup>
<b>SD-500</b>	25 <sup>9/10</sup>	22	32 <sup>3/4</sup>

- Hands-free ice machine/dispenser
- Optional stand
- Optional stand with locking doors

## AIR-COOLED

Water Temp ° F.	50°	70°	90°
Air Temp ° F. 70°	321	307	291
80°	277	263	249
90°	237	232	214

## UTILITY CONSUMPTION

Model Number	Approximate Electrical		KWH per 100 LBS.	
	90/70	70/50	90/70	70/50
DCM-300BAH-OS	661W	653W	6.84	4.88

## SPECIFICATIONS

Model Number	Condenser	Amperage	Min. Circuit Ampacity	Shipping Weight
DCM-300BAH-OS	Air-Cooled	10.25	20	240 lbs.
SD-450	N/A	N/A	N/A	110 lbs.
SD-500	N/A	N/A	N/A	98 lbs.

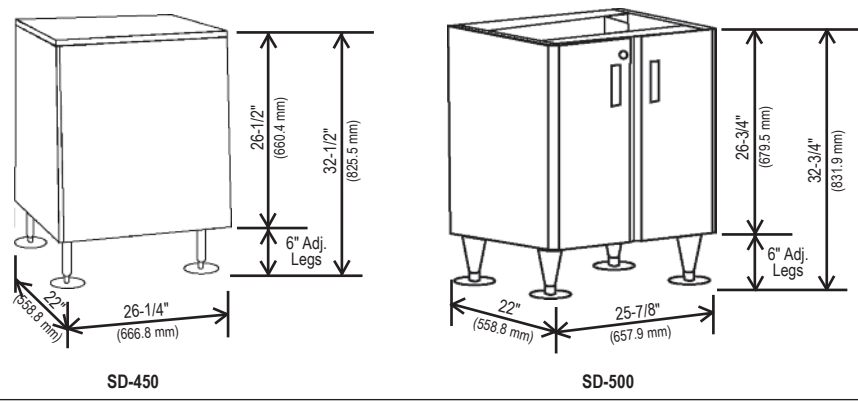
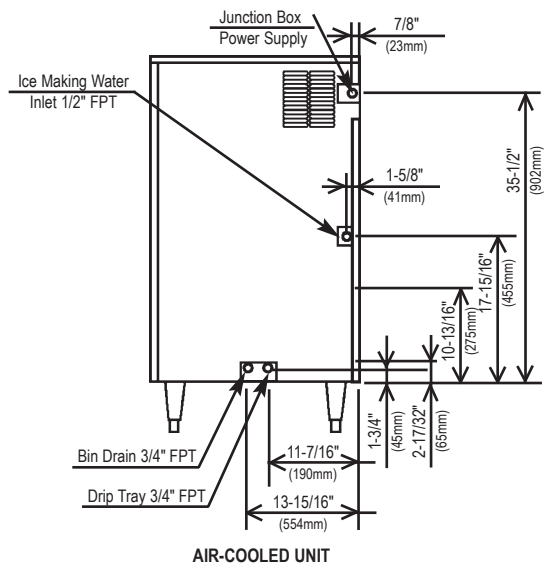
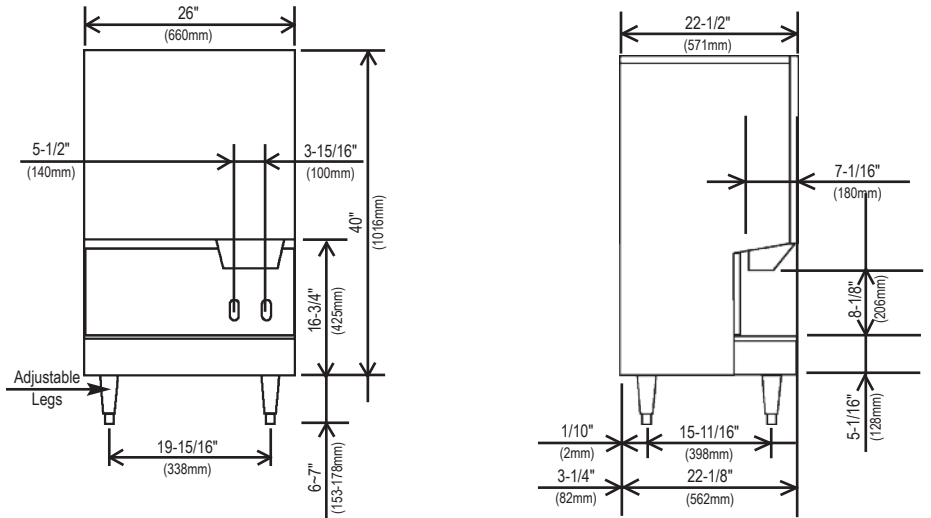

## ELECTRICAL & PLUMBING/DCM-300BAH-OS

- 115V/60/1
- 20 amp Max Fuse Size
- 1/2" OD copper or equivalent independent water supply
- 3/4" independent drain connection

## OPERATING LIMITS

• Ambient Temp Range	45 - 100°F
• Water Temp Range	45 - 90°F
• Water Pressure	10 - 113psig
• Voltage Range	104 - 127V

## SERVICE

- Panels easily removed and all components accessible for service.
- Removable/cleanable air filter.

